

## **Guidelines for Collocation and Unbundled Loop Test Access Points**

This document clarifies the Competitive Local Exchange Carrier (CLEC) test access points within Qwest central offices where a CLEC may have physical collocation space. The CLECs may access the test points, defined in this document and the attached drawings, for the purpose of testing and maintenance of the equipment cable terminations. Once the physical collocation site build has been completed and the CLEC accepted it, access is granted. CLECs with physical collocation sites in a given office have 24x7 access including test access. For purposes of this document, physical collocation includes: Caged Physical collocation, Cageless Physical collocation, Shared Caged collocation, ICDF collocation and Common Area Splitter collocation. CLEC access for testing is limited to those locations applicable to the type of collocation(s) they have purchased.

The equipment cable is the cable extending from a physical collocation area to an appropriate cross-connect device within the Qwest central office. Typically, this cross connection occurs on an interconnection distribution frame (ICDF)<sup>1</sup> of some sort and the resulting termination point (from the collocation space) is often referred to as the point of demarcation or "DMARC" and may also be referred to as the "CFA" or Connecting Facility Assignment location. The equipment cable to this termination point is provided by either the CLEC or, upon request and for a price, Qwest. The CLEC owns the cable between the ICDF and their collocation space (in the case of ICDF collocation, they own the jumper between the ICDF blocks but not any of the cable going to the ICDF). Since Qwest does not own or maintain this cable, the CLEC must have access to both termination points should any maintenance or trouble occur on the equipment cable itself. Test access points for the CLEC do not change based upon who provided the cable.

The following drawings are intended to illustrate and clarify the test points in several situations but are provided as guidance only, there may be other circumstances that arise requiring an individual case basis analysis:

- Physical (Caged, Cageless, Shared) Collocation with Shared Fiber Entrance Facility
- Line Sharing with Common Area Splitter
- ICDF Collocation
- Virtual Collocation
- Facility Connected Collocation
- DS0 Level Services
- DS1 Level Services
- DS3 Level Services

---

<sup>1</sup> For purposes of this document, the ICDF termination point may be located on, but is not limited to, a main distributing frame (MDF), fiber distribution panel (FDP), and existing Digital Cross Connect (DSX) frames for DS1 and DS3 services.

CONFIDENTIAL: Disclose and Distribute Solely to Those with a Need to Know

### ***Testing of fiber entrance facility***

#### EXPRESS Fiber

- CLECs provide their fiber cable to the Collocation Point of Interconnection (C-POI) leaving enough fire rated fiber in this designated manhole to allow Qwest personnel to pull from that point through manhole 0 and the vault to the collocation space. Qwest does not test this fiber run. CLECs may test this fiber from their collocation space and need no other access for testing of this facility as there is no intermediate termination point between the C-POI and the collocation space.

#### SHARED Fiber

- CLECs provide their fiber cable to the Collocation Point of Interconnection (C-POI). Qwest personnel then splice it to Qwest fiber and run the fiber (where needed) to the appropriate fiber distribution panel (FDP) and install cable from the collocation space to the FDP and place jumpers on the FDP to link to the collocation space.
- Qwest tests the fiber for continuity between the C-POI splice and the FDP.
- Since jumpers are from the factory, no separate test is performed on the jumper at the time of installation between the collocation termination and the facility to the outside plant.
- Test access is limited at the FDP because of the sensitivity and intrusiveness of the termination disconnection required to enable testing. The disconnection may impact more than just the CLEC attempting to test; therefore, Qwest recommends a cooperative test be requested.

### ***Testing of CLEC Equipment Cable for Physical Collocation in the Central Office***

- The CLECs have the capability to test the equipment cable for continuity between their physical collocation site and the appropriate cross connect device. Access is limited to the collocation side of the termination. CLECs currently have access to the ICDF for testing and, when they have ICDF collocation, to run jumpers to connect unbundled network elements (UNEs).
- If the CLEC experiences a problem with the cable provisioned by the collocation order, they may utilize the Qwest maintenance and repair process submitting a trouble ticket where indicated.
- If the CLEC would like to arrange joint testing for continuity purposes between the collocation space and the Qwest side of the collocation termination, they may submit this request by referring to the Wholesale Collocation PCAT and following the instructions for joint testing.

CONFIDENTIAL: Disclose and Distribute Solely to Those with a Need to Know

Physical (Caged or Cageless) Collocation with a Shared Fiber Entrance Facility

**Test Points**

**A** - CLEC tests fiber from their network to C-POI

**B** - Qwest tests shared fiber for continuity from the C-POI to the FDP

**C** - CLEC tests from the collocation space to the FDP

**D** - CLEC tests from the collocation space to the test points on the vertical side of the ICDF for DS0 terminations. For DS1 and DS3 terminations, CLEC tests to the test access points on the DSX.

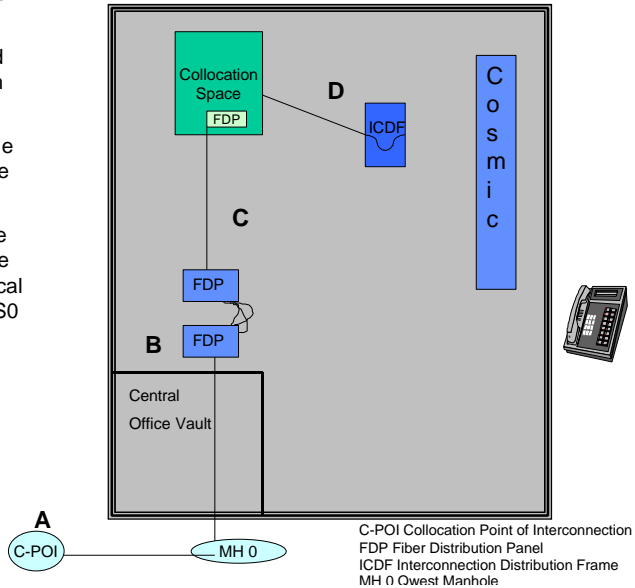

**Testing at the DMARC for Virtual Collocation in the Central Office and of Facility Connected Collocation**

- Qwest processes allow CLECs with virtual collocations physical access to the point of demarcation between the Qwest network and their network (DMARC).
- CLECs choosing to utilize Facility Connected Collocation will have physical access to the point where the entrance terminates - ICDF, FDP or other frame.
- However, access for both of these types of collocation must be *coordinated with the SICM* unless the CLEC also has a Physical Collocation in the same central office allowing them entry to the building.
- Like other collocation testing points, the ICDF normally contains the test access point for virtual collocation - Point D above.
- By contrast, when utilizing Facility Connected Collo (fiber), the test point would be at the FDP; however, since testing of these fiber terminations involves significant intrusion, Qwest recommends a cooperative test be arranged.

**Testing of ICDF Collocation**

- CLECs with only ICDF collocation in the Central Office have access to both the horizontal side and the vertical side of the ICDF to place the jumper combining elements as well as for testing.

**Testing of Line Sharing with CLEC Common Area Splitter**

CONFIDENTIAL: Disclose and Distribute Solely to Those with a Need to Know

- CLECs with Physical Collocation have test access to the collocation terminations on the ICDF including voice, voice and data, and data terminations.
  - Access to the data only termination usually occurs on the 410 block of the ICDF
  - Alternatively, if an 89 block was placed, the CLEC may access both the voice and voice/data terminations which appear typically on the horizontal side
- CLECs with Physical Collocation also have "pin" access to the back of the common area splitter.
- CLECs without physical collocation have "pin" access to the back of the common area splitter.

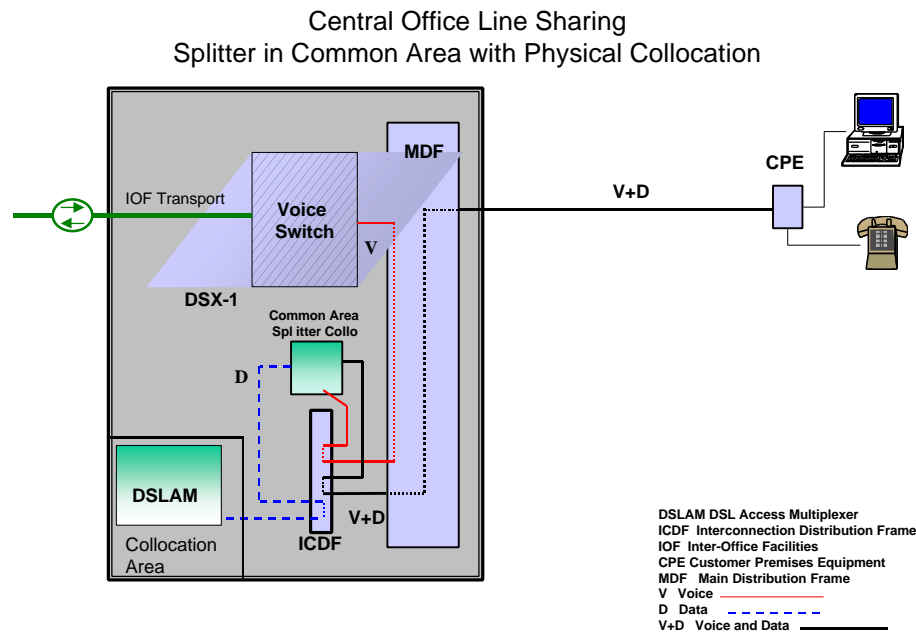

### ***Testing of the Unbundled Element***

Qwest processes are documented for testing of unbundled elements as they are ordered, provisioned and installed. Technical parameters are documented in Technical Publication 77384.

### ***Test Point(s) at a DS-0 Level***

At the DS-0 level, the CLEC will have test access at the vertical side of the ICDF where applicable, or to the terminal block within the collocation space in those offices without ICDFs. The test access point for the DS-0 is no different than from the collocation space - that point at which the CLEC's equipment cable that originates in the collocation space terminates.

CONFIDENTIAL: Disclose and Distribute Solely to Those with a Need to Know

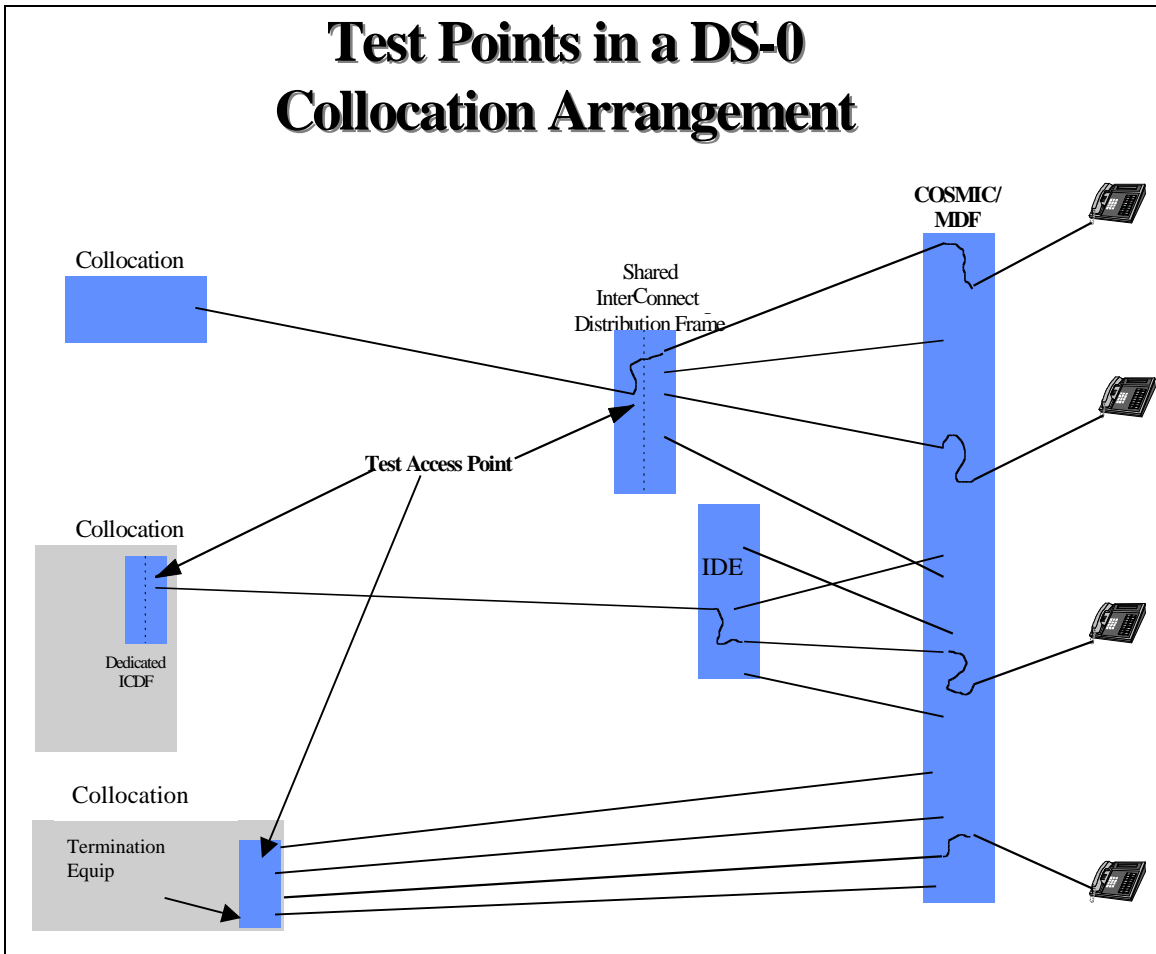

CONFIDENTIAL: Disclose and Distribute Solely to Those with a Need to Know

### **Test Point(s) at a DS-1 Level**

At the DS-1 level, the CLEC can test at either the Shared ICDF, DSX, or if applicable, at a dedicated frame within their collocation space - either caged or cageless physical. The following drawing documents those points. In addition, CLECs test where their cable terminates on the DSX1 Panel.

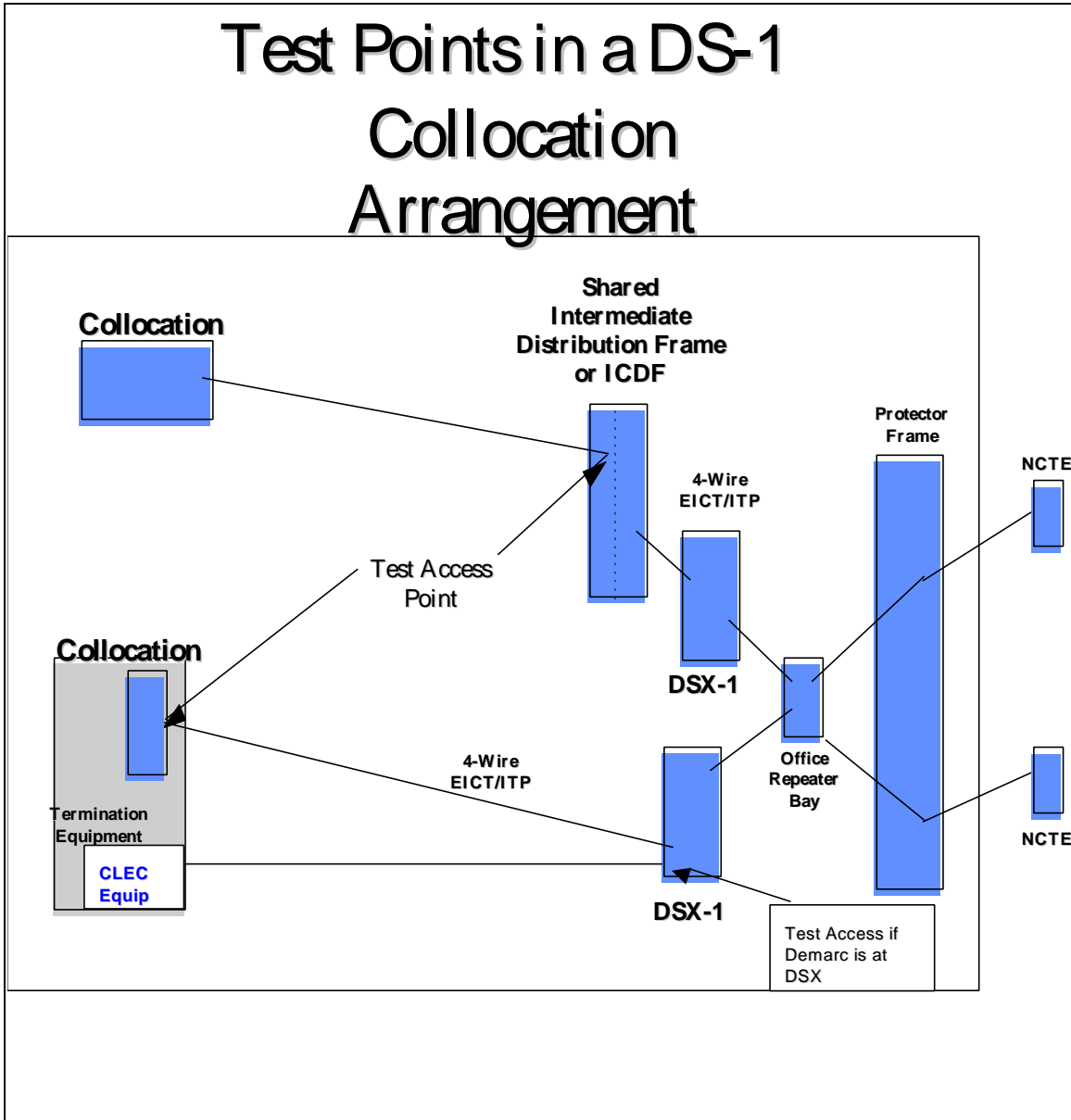

CONFIDENTIAL: Disclose and Distribute Solely to Those with a Need to Know

### ***Test Point(s) at a DS-3 Level***

At a DS-3 level, the CLEC may test at either the Shared ICDF, DSX frame or at a dedicated DSX-3 panel within the CLECs collocation space - either caged or cageless physical. The following drawing documents those points.

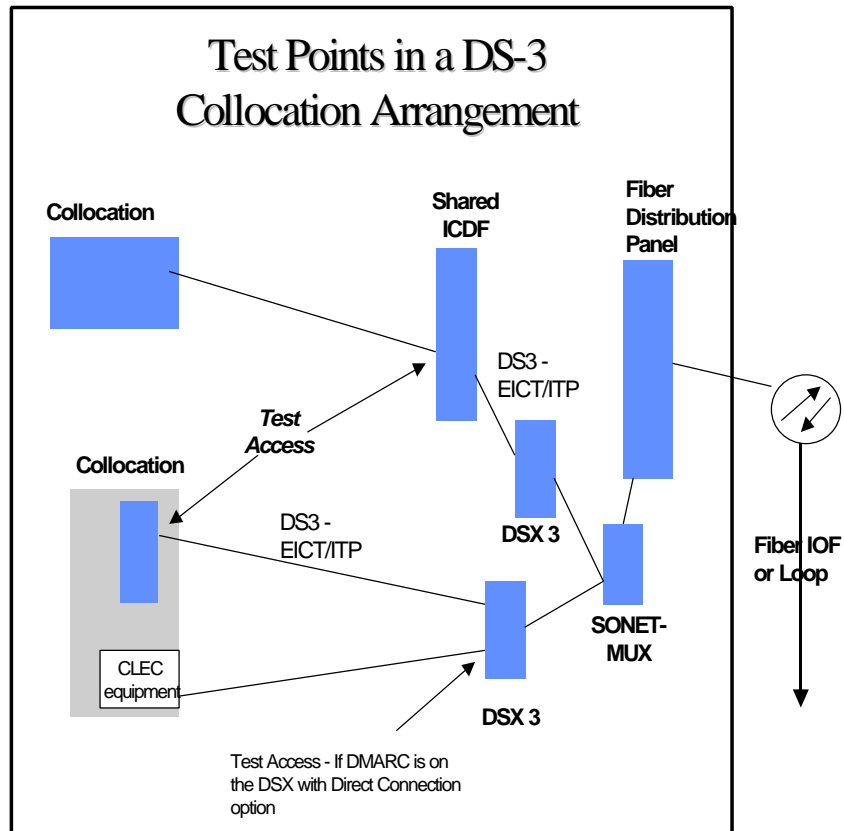

CONFIDENTIAL: Disclose and Distribute Solely to Those with a Need to Know

DRAFT DRAFT  
For Discussion Purposes Only  
Version 3.3, July 8, 2002  
Local Network, Technical Regulatory Interconnection Planning  
Central Office Process Staff

CONFIDENTIAL: Disclose and Distribute Solely to Those with a Need to Know